

A62JRT

ARTICULATED BOOM LIFT



- High performance articulated boom lift
- Class-leading working envelope
- Powerful 4 wheel drive with oscillating axle
- Ultra-tight turning radius
- Compact dimensions and zero tailswing

 **snorkel**
www.snorkellifts.com

ARTICULATED BOOM LIFT

A62JRT

DIMENSIONS	A62JRT
Max. working height	20.8m
Max. platform height	18.8m
Max. working outreach	11.1m
Clearance height at max. outreach	9.0m
Platform size	2.4m x 1.0m
Overall width (A)	2.4m
Transport length	8.5m
Overall length (B)	8.6m
Stowed height (C)	2.6m
Ground clearance	350mm

PERFORMANCE	
Platform capacity (SWL)	227kg
Max. drive height	18.8m
Max. drive speed (stowed)	6.1km/hr
Max. drive speed (elevated)	1.2km/hr
Jib length	1.8m
Jib working arc	136°
Platform rotation	180°
Turret rotation (continuous)	360°
Tailswing	0m
Gradeability	45%
Inside turning radius	1.4m
Outside turning radius	4.6m
Tyres	335/55 D625 foam filled lug
Controls	multi-function, proportional drive, raise and slew
Drive system	4WD hydrostatic with oscillating axle

POWER	
Power source	Kubota V2403M-T 44kW/59HP

WEIGHT	
Gross weight	10,659kg

WORKING ENVELOPE

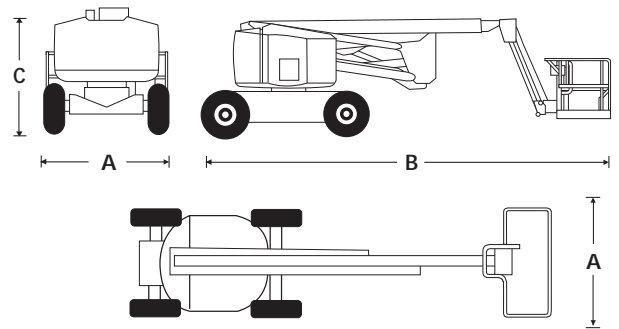
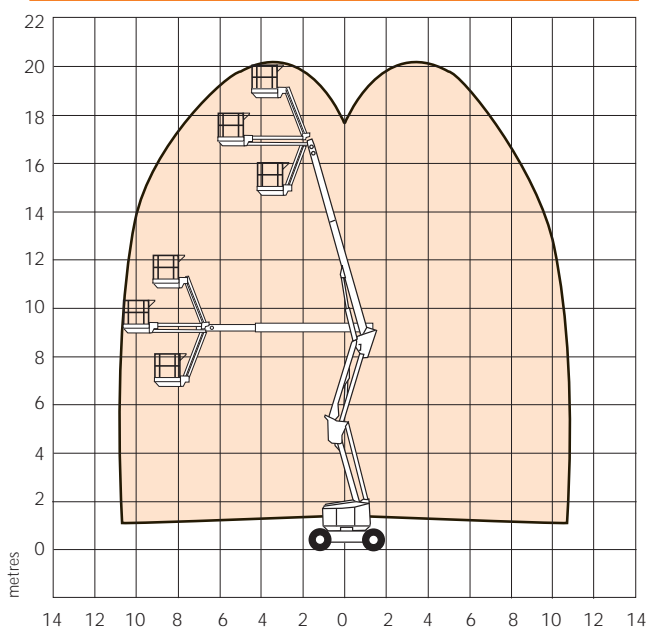

STANDARD FEATURES

- Powerful hydrostatic 4 wheel drive
- Oscillating axle
- Zero tailswing
- Ultra-tight turning radius
- Swing-out engine tray
- Hour meter
- Horn
- Flashing amber light
- Power line to platform (no sockets)
- Three entry platform
- DC emergency operation
- CE approved

OPTIONS

- Special paint colours
- Dual fuel power source
- Motion alarm
- Poly-filled tyres
- 1.8m x 1.0m platform
- 2kW generator
- Glazier package
- On-board welder
- Extreme environment package
- Lights package
- Cold weather package
- Aircraft package

snorkel www.snorkellifts.com

2/26 Redfern Street,
Wetherill Park,
NSW 2164, Australia
t: +61 1300 900 700
e: sales.au@snorkellifts.com